

kvik

C648,061

Method 1 (Thermex)

Method 2 (Siemens)

DC48,***,***

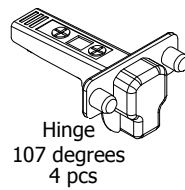
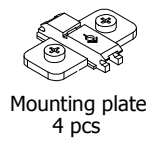
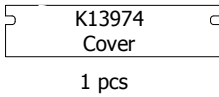
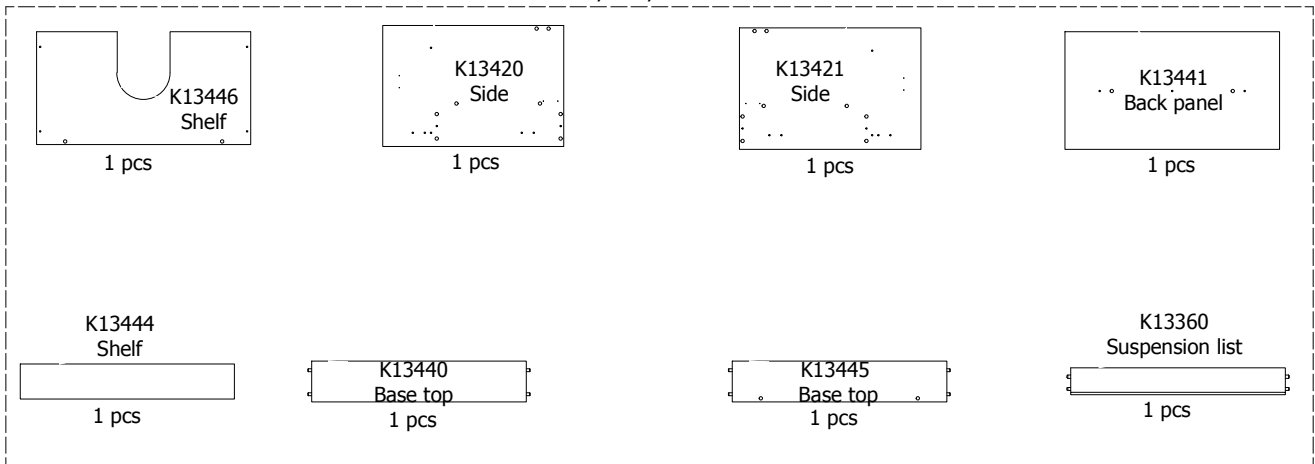

BP00029

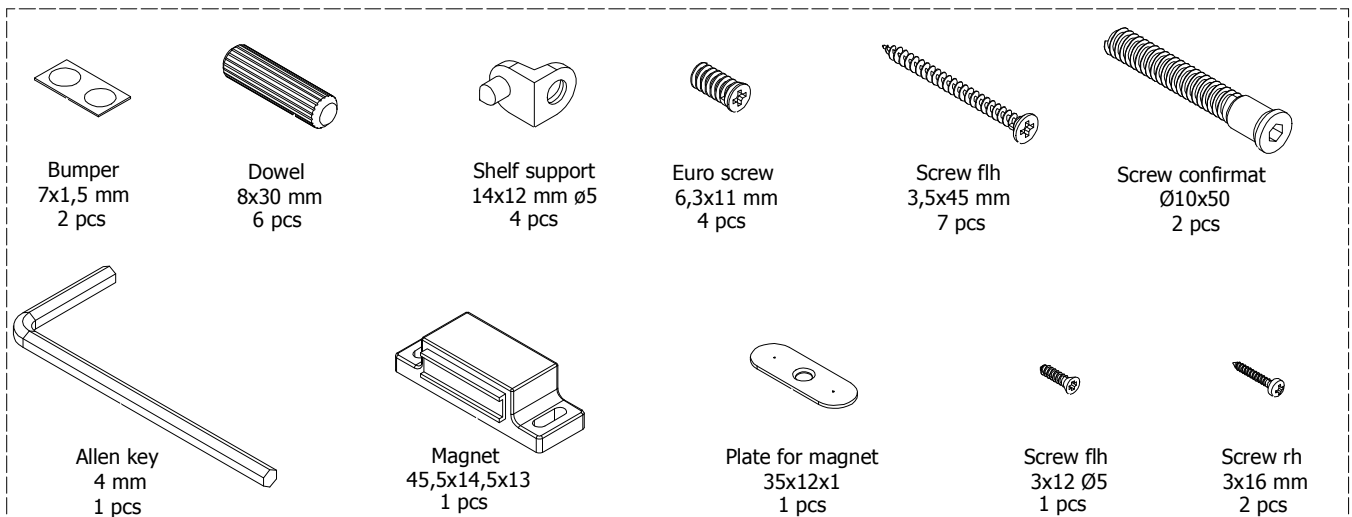

Method 1 (Thermex)

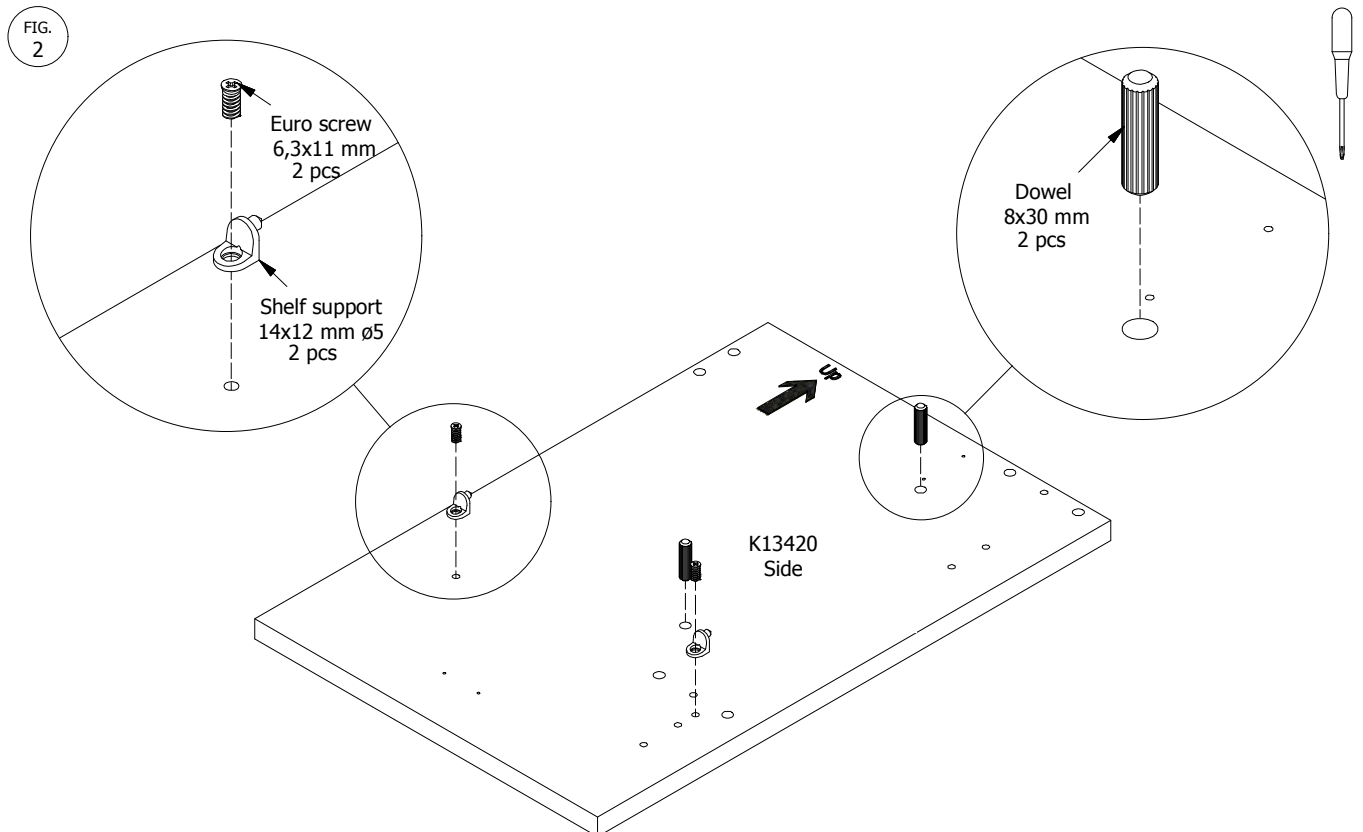
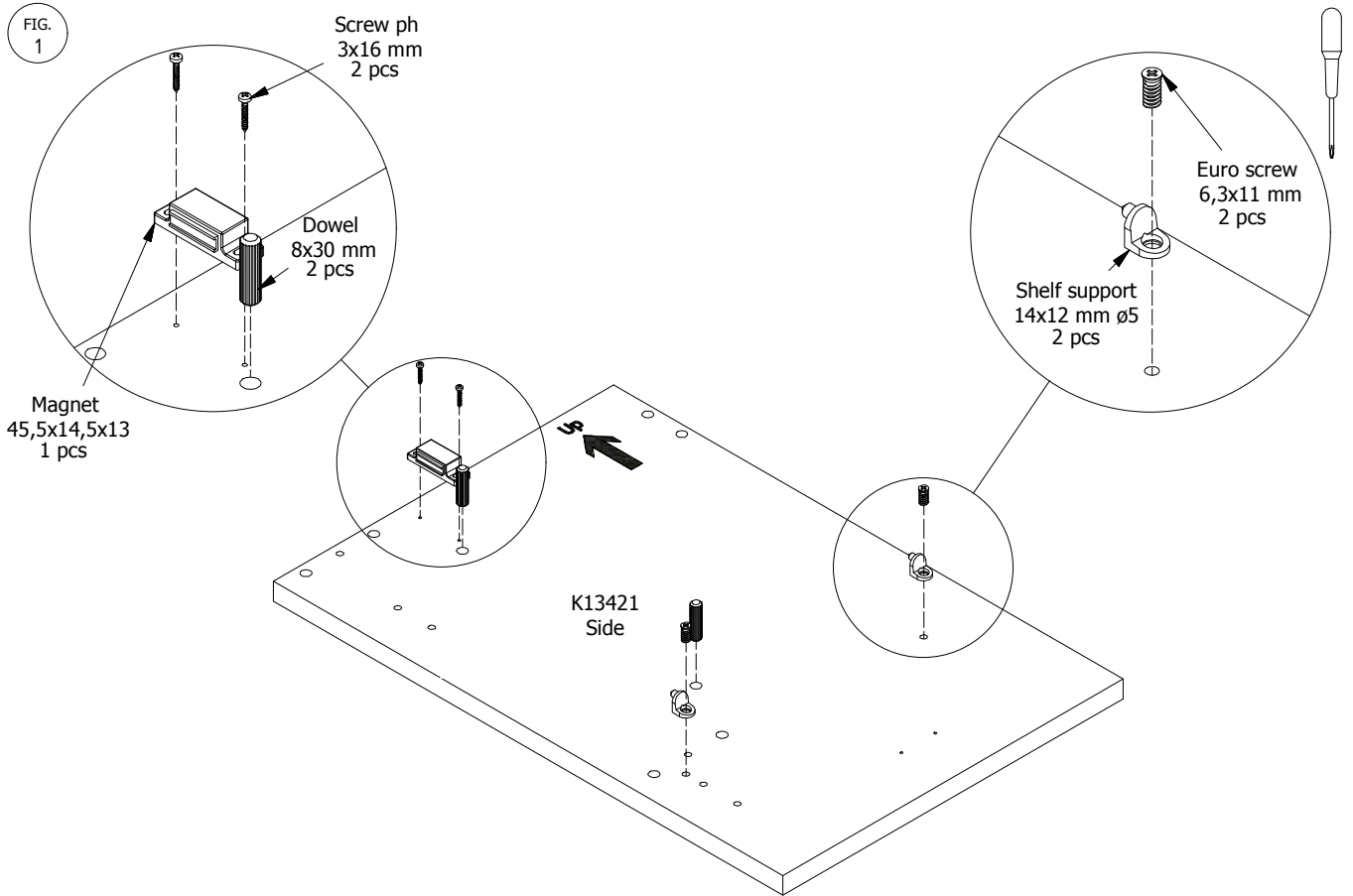

FIG. 3

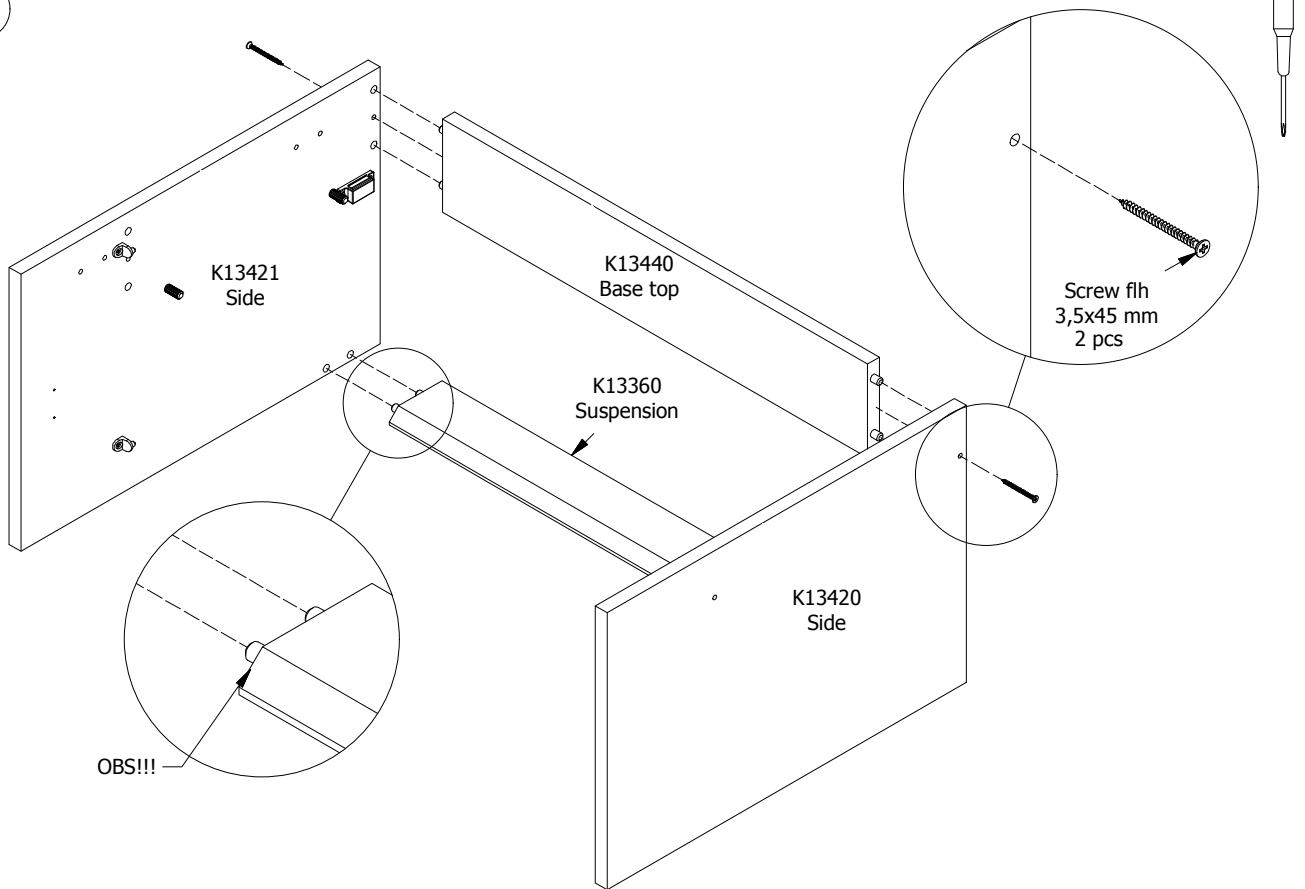

FIG. 4

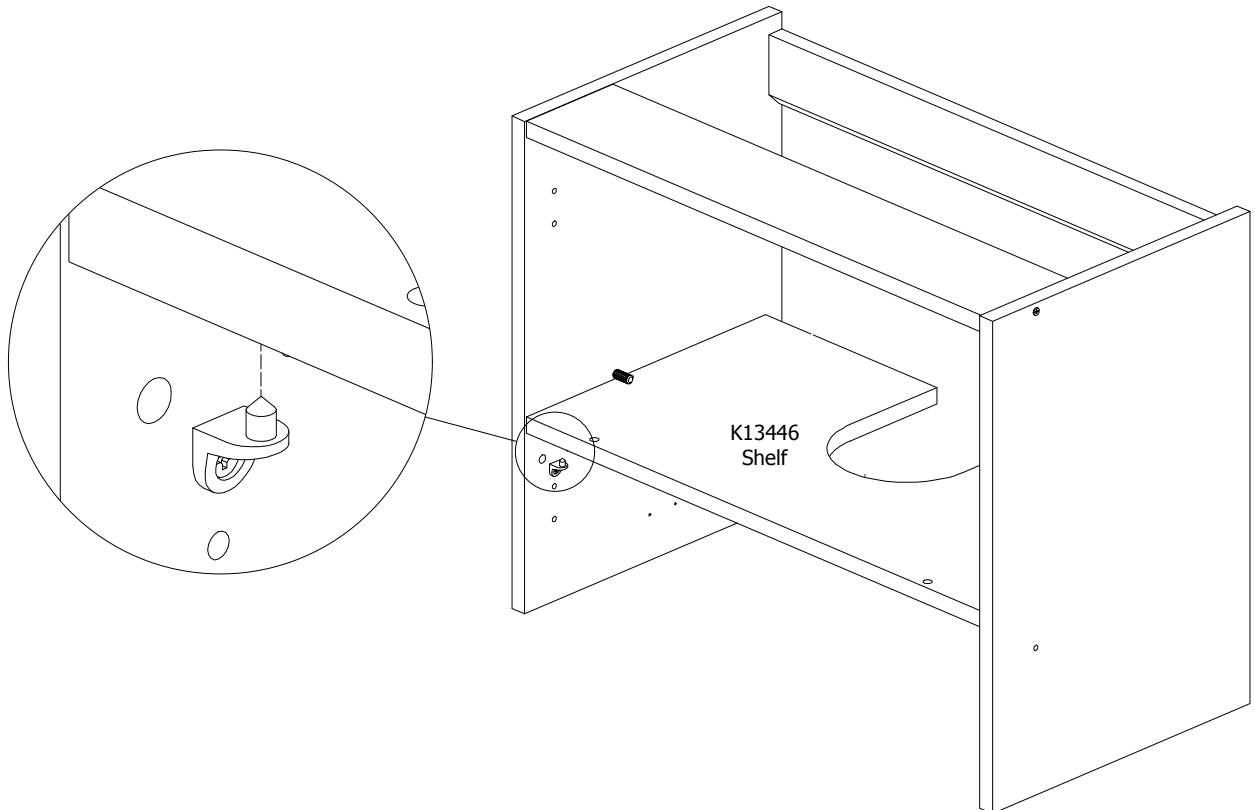

FIG. 5

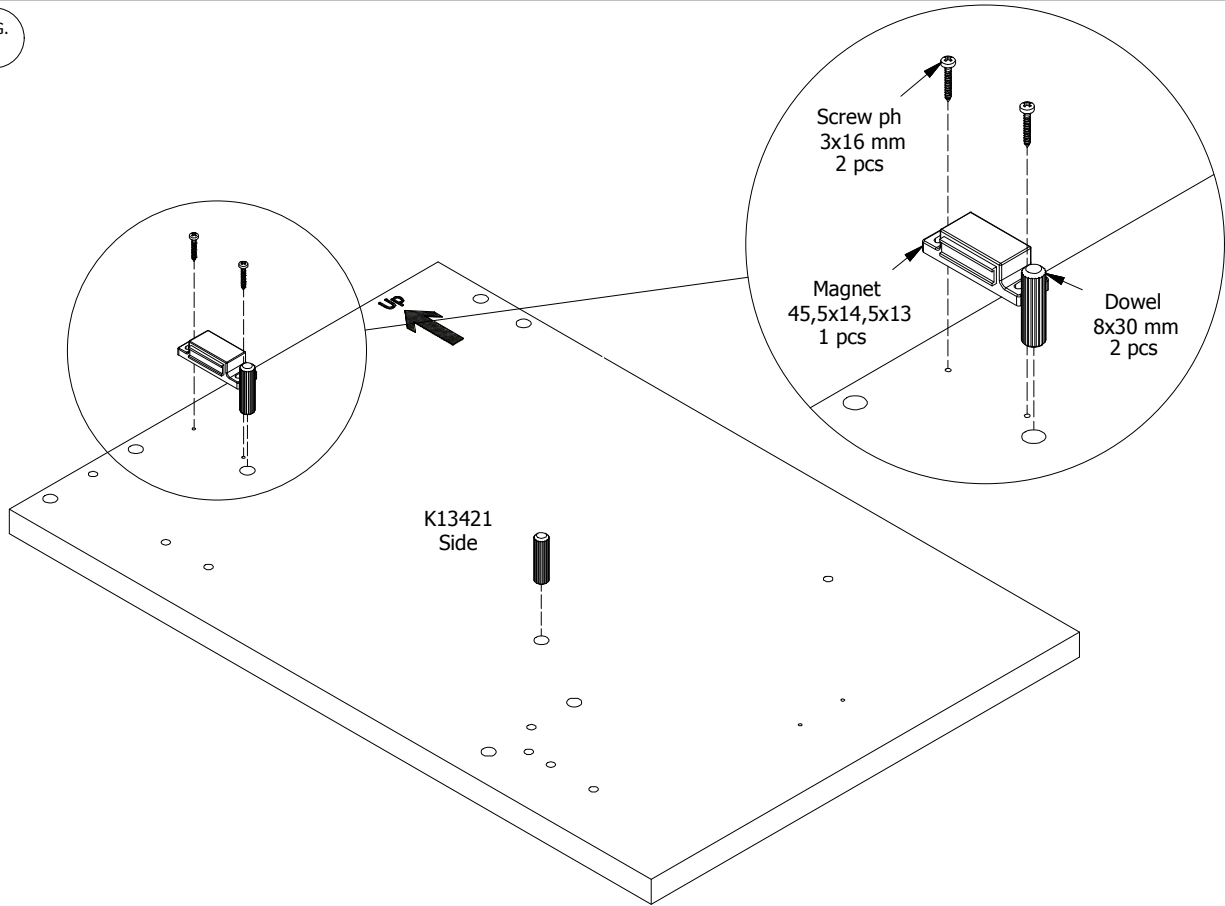
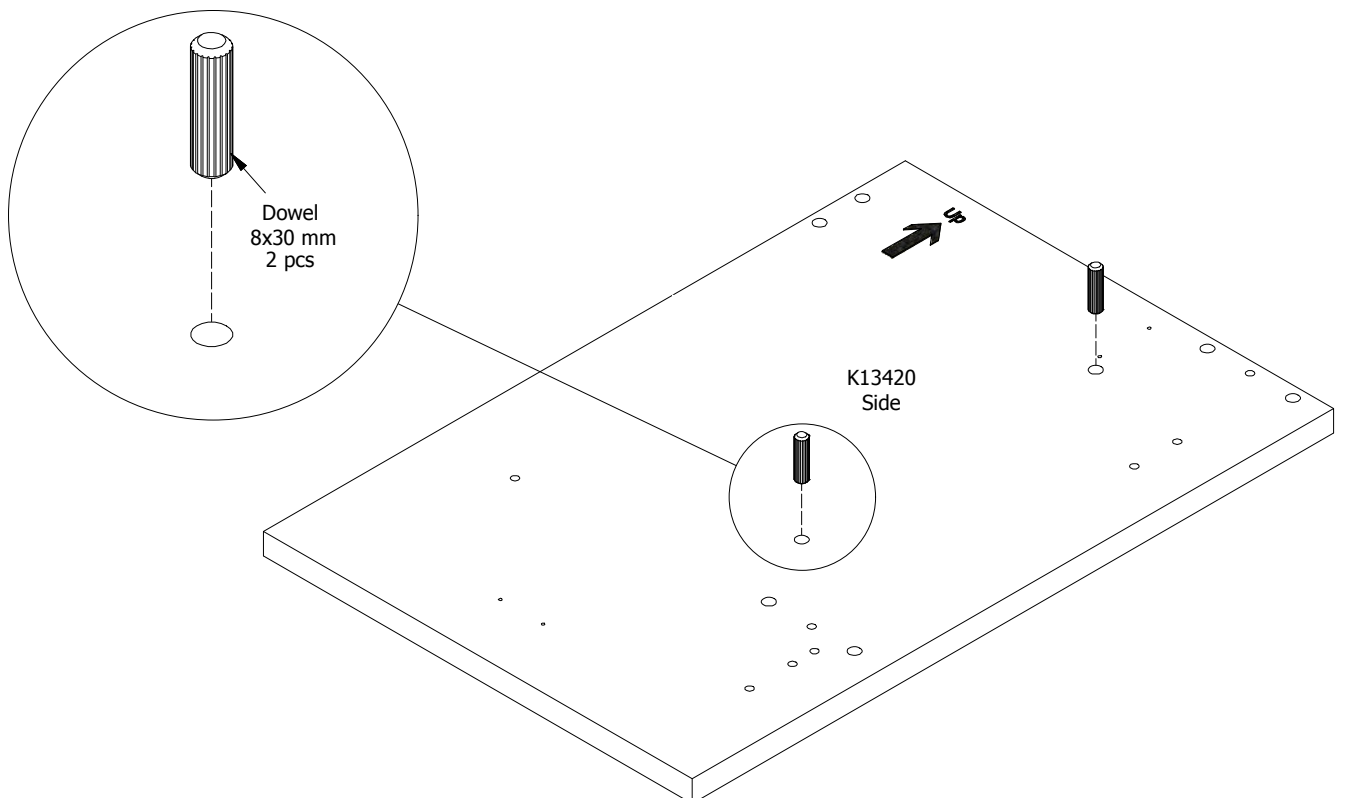

FIG. 6



Method 2 (Siemens)

FIG. 7

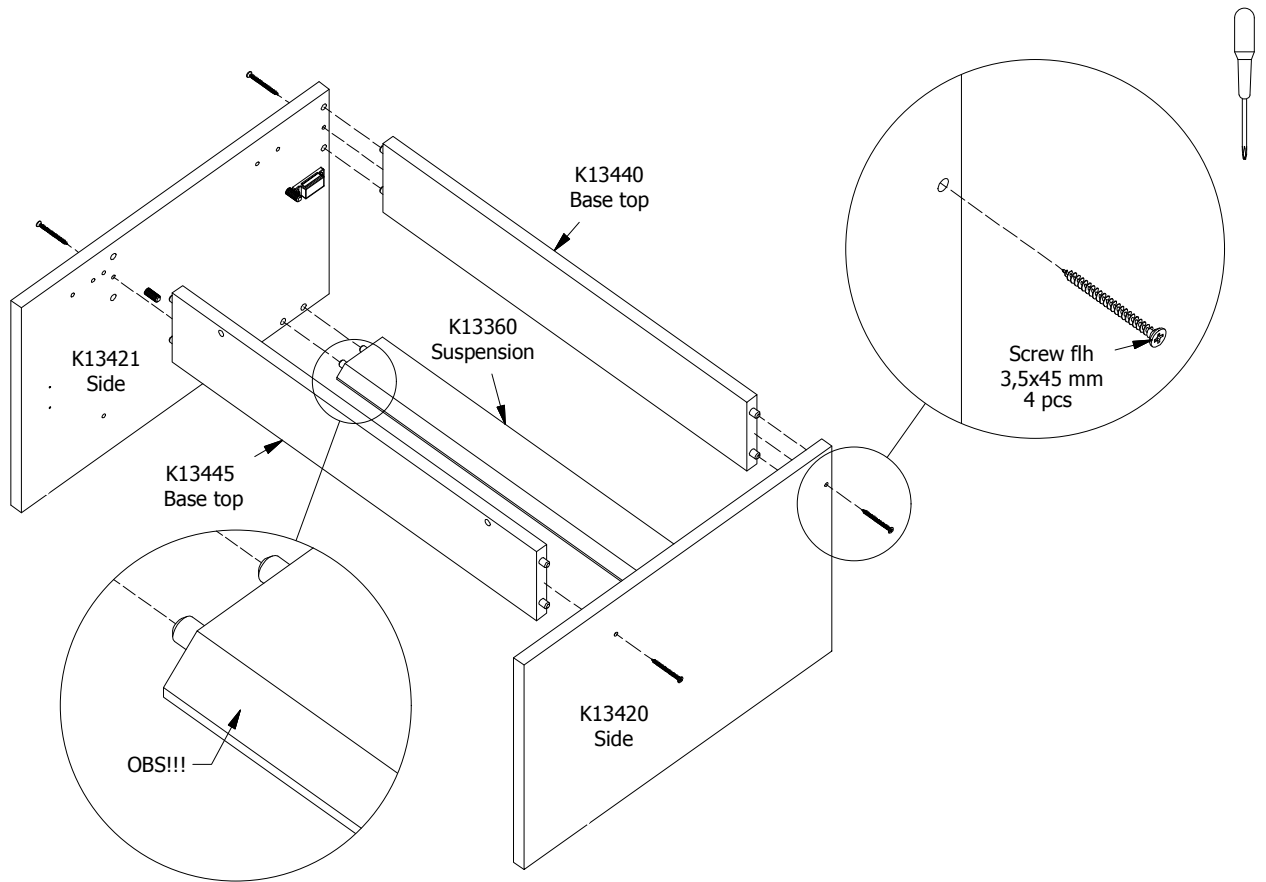

FIG. 8

Method 1 and 2

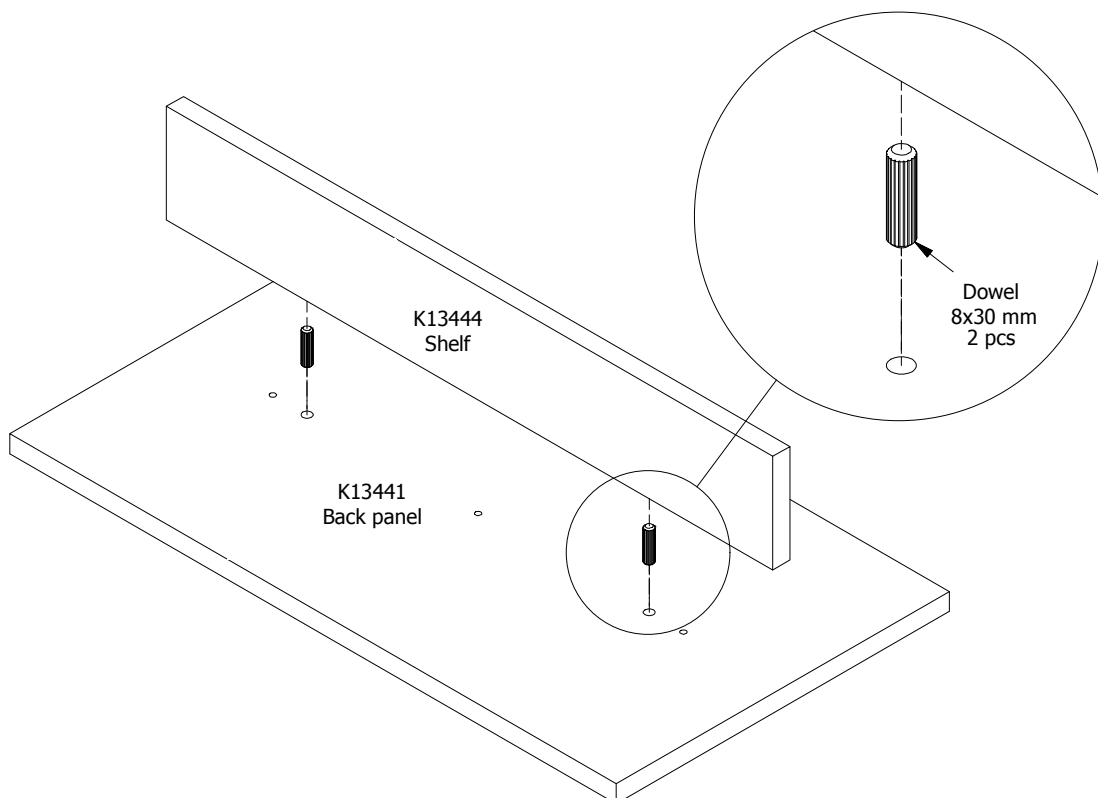

FIG. 9

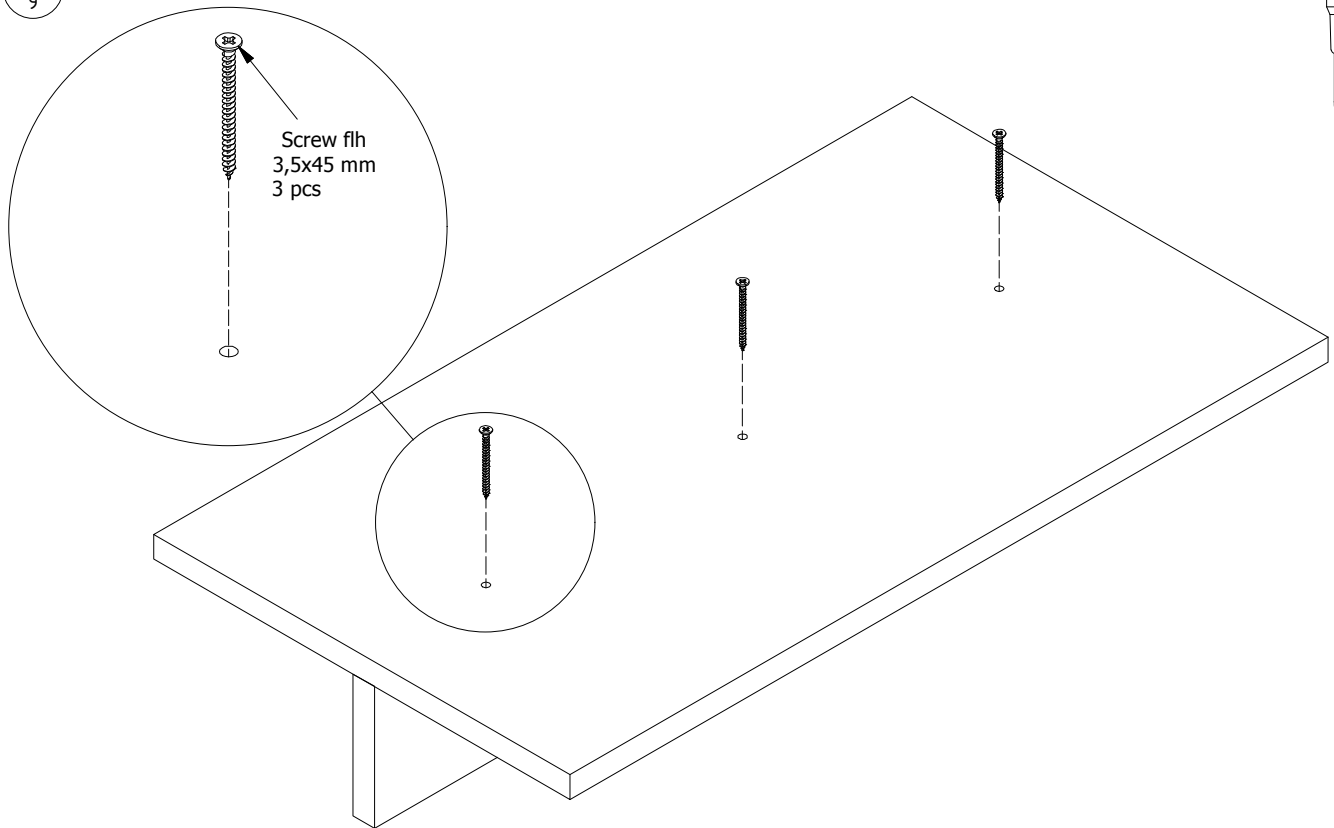

FIG. 10

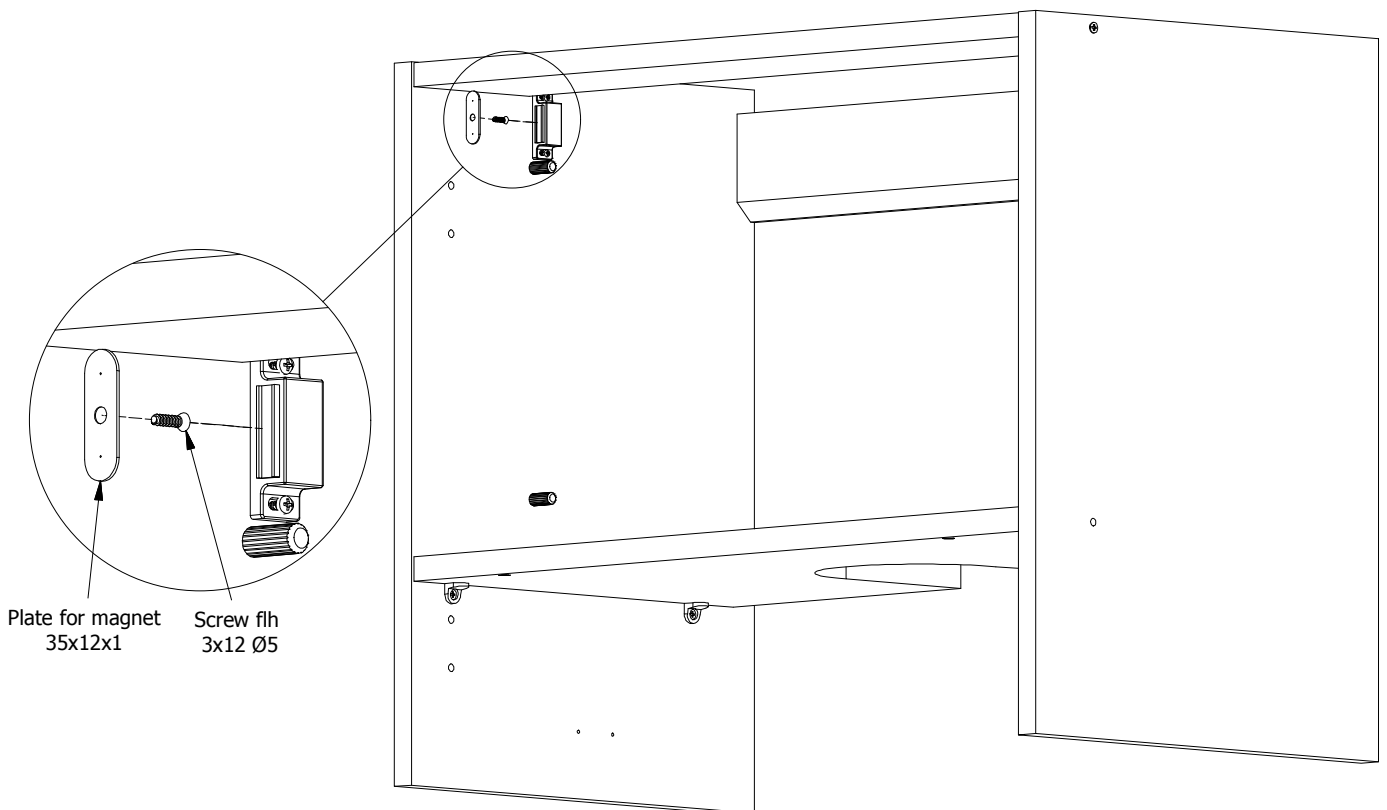

FIG. 11

Push, and the screw will make a mark on the backside, to use to mount the plate for magnet

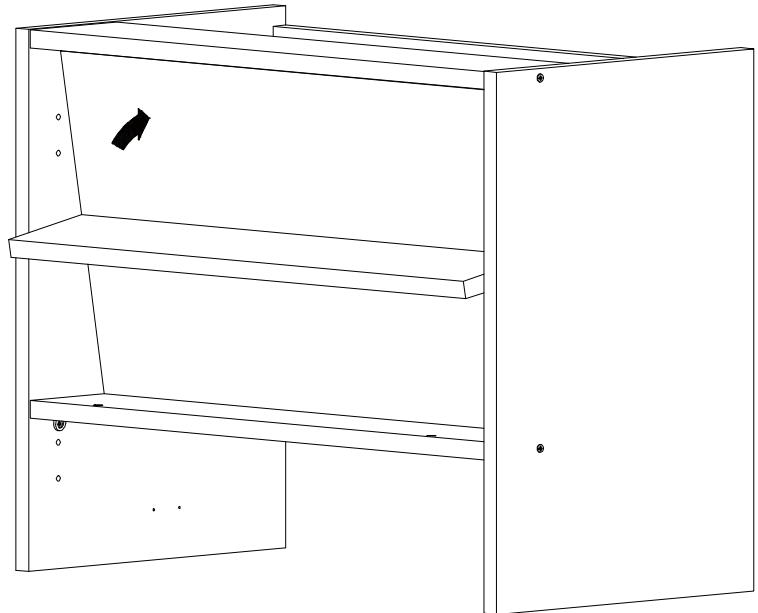

FIG. 12

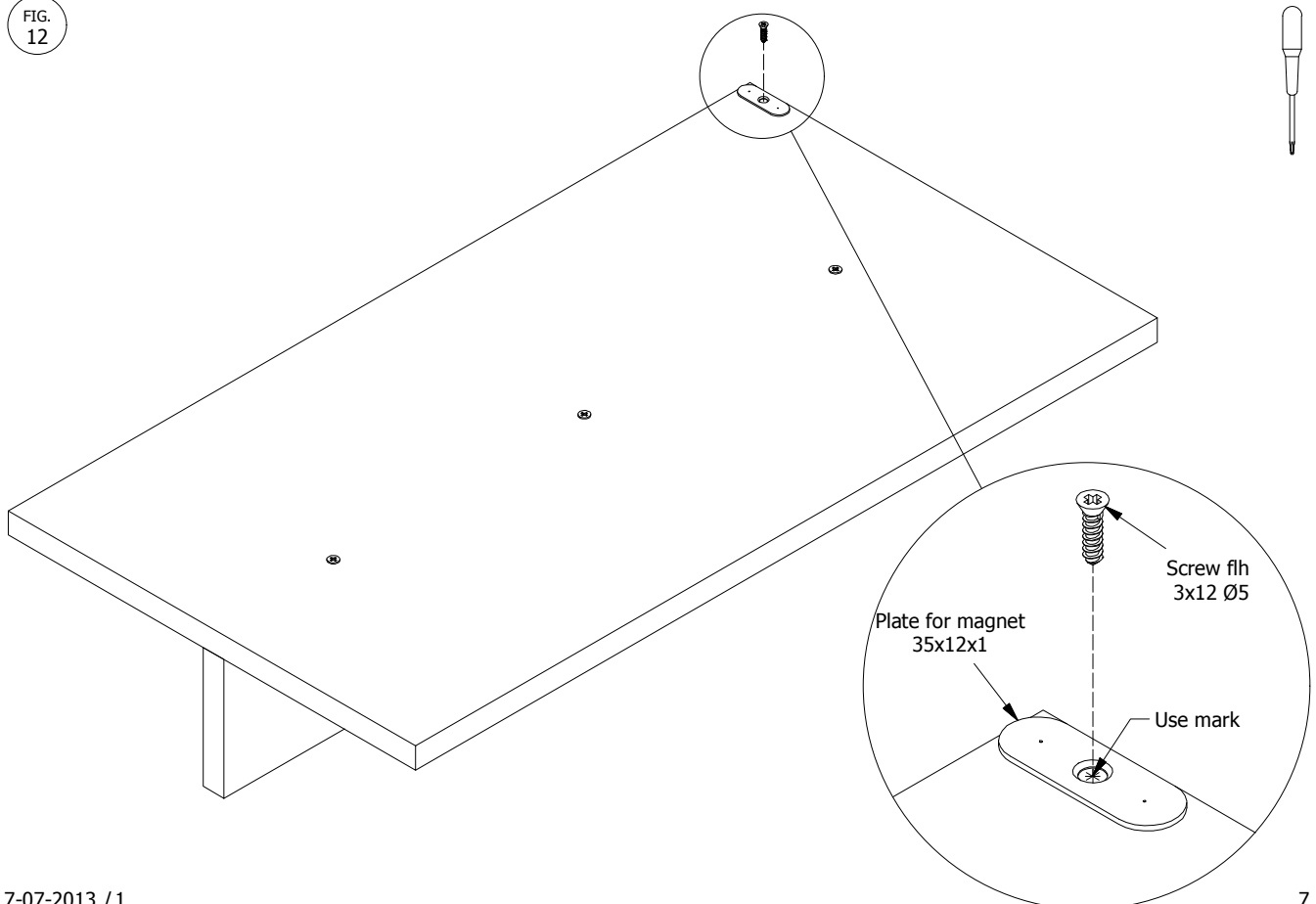

FIG. 13

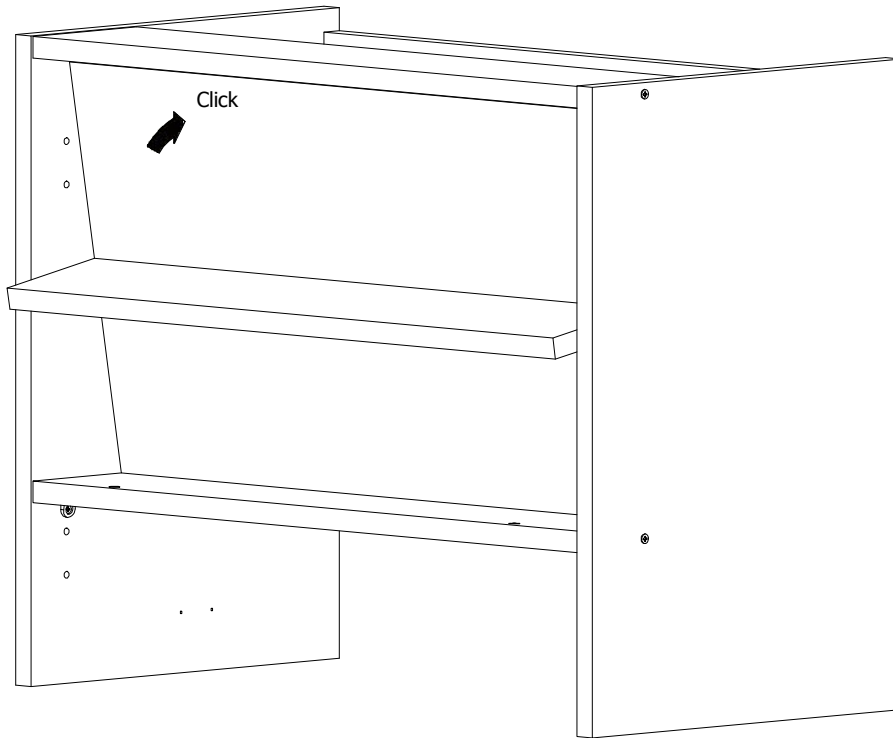

Fig 14

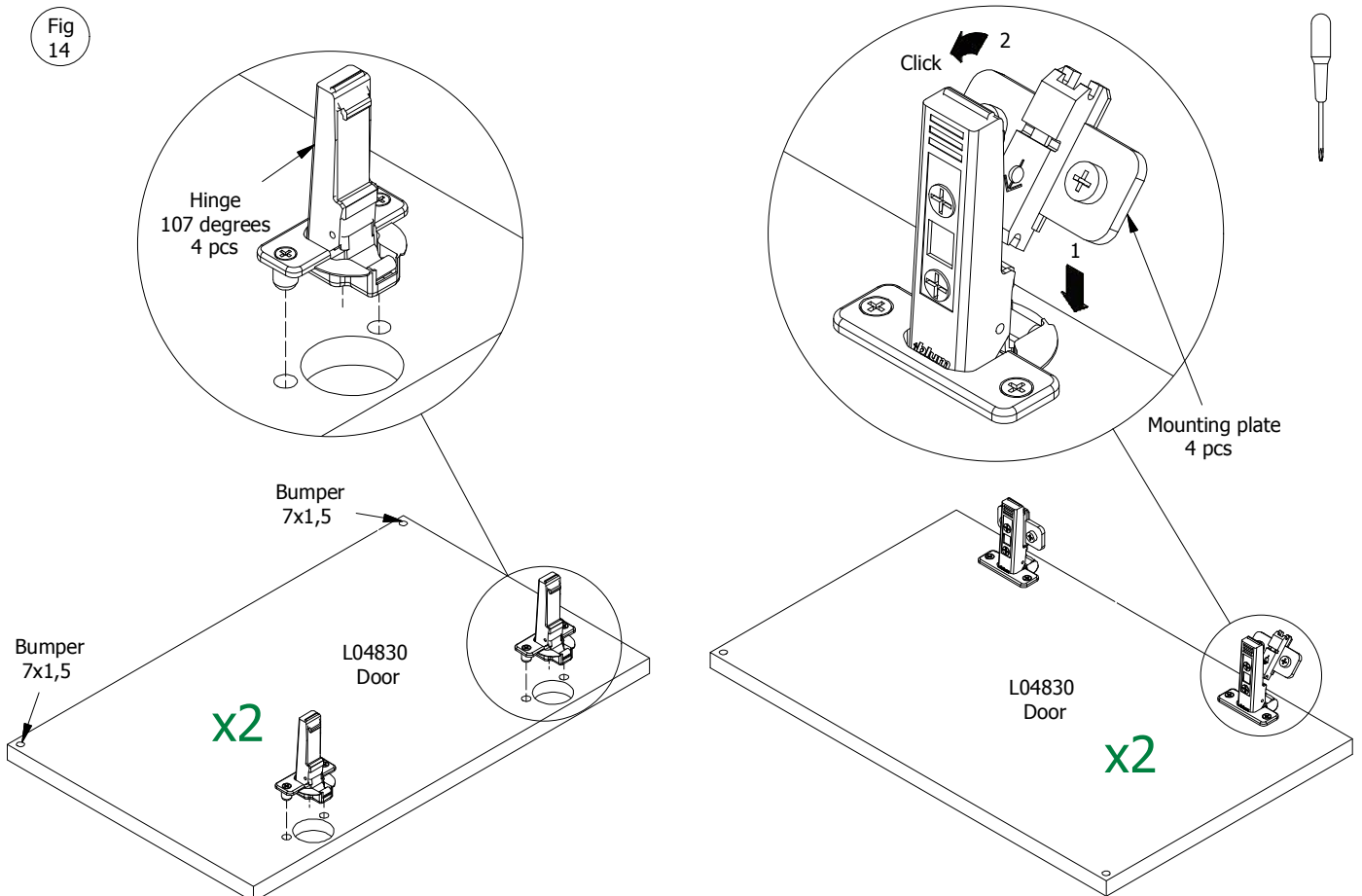

Fig 15

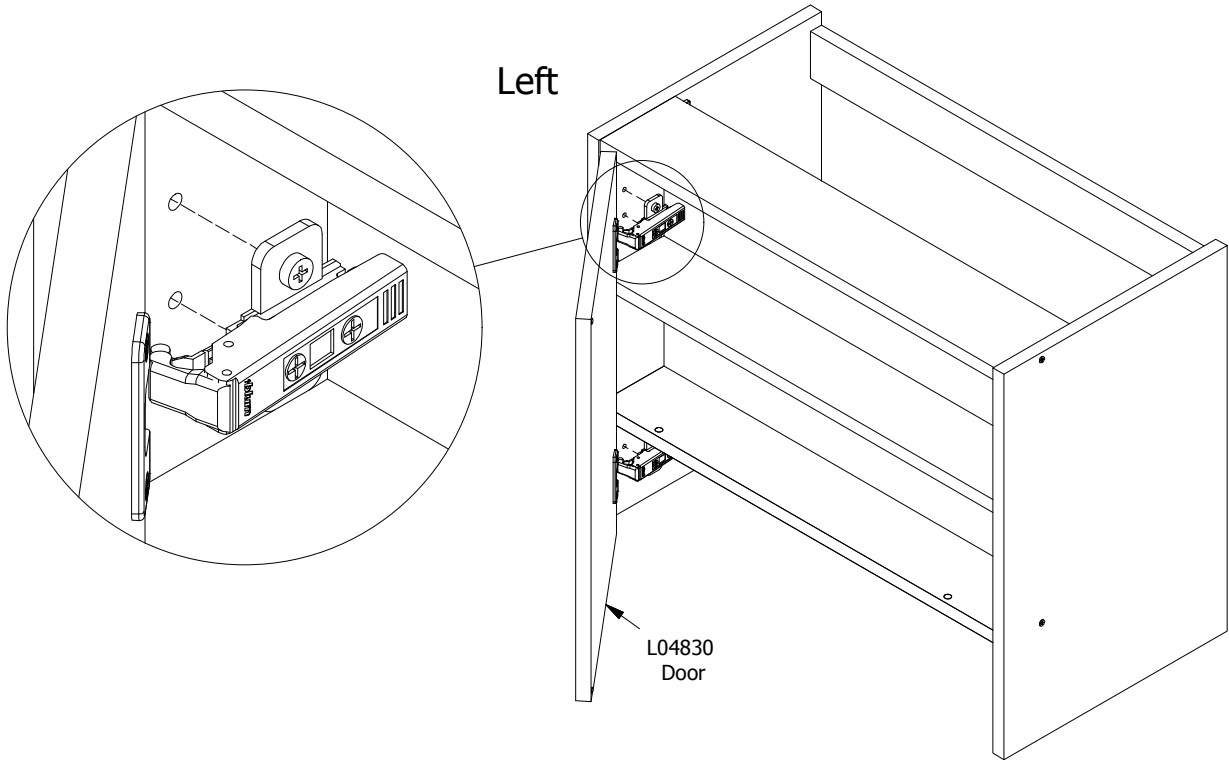

Fig 16

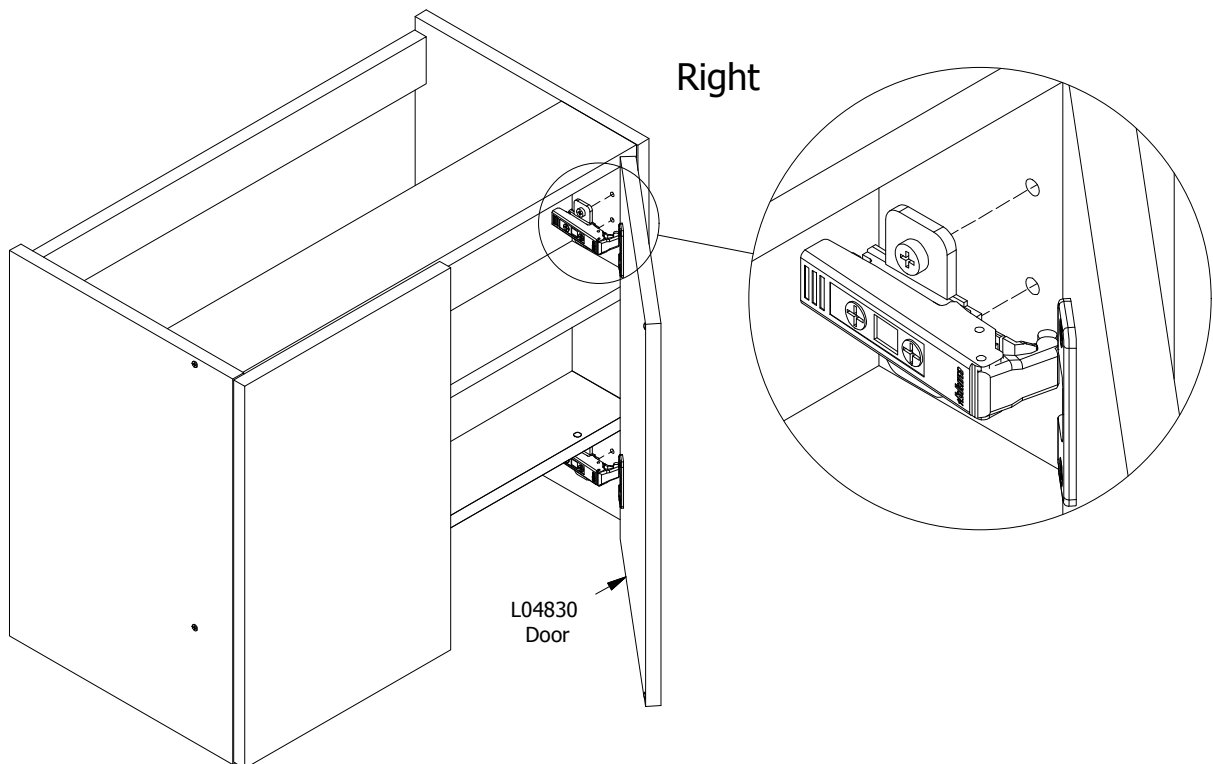

Fig 17

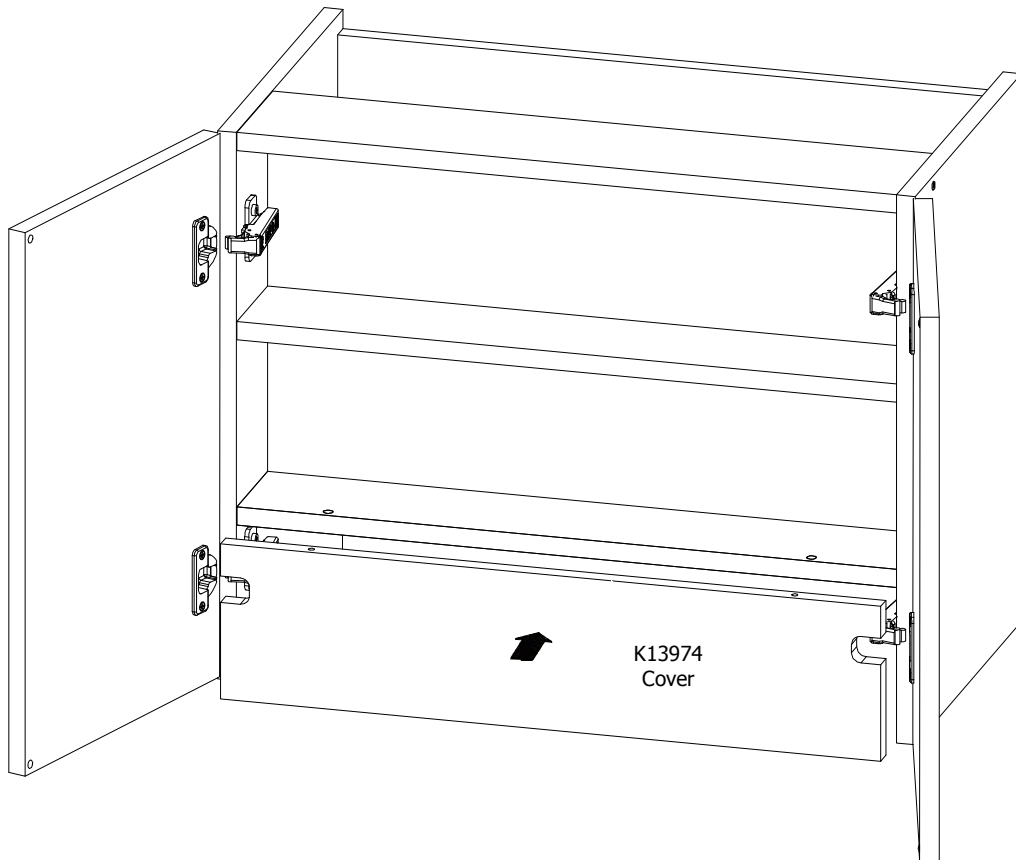
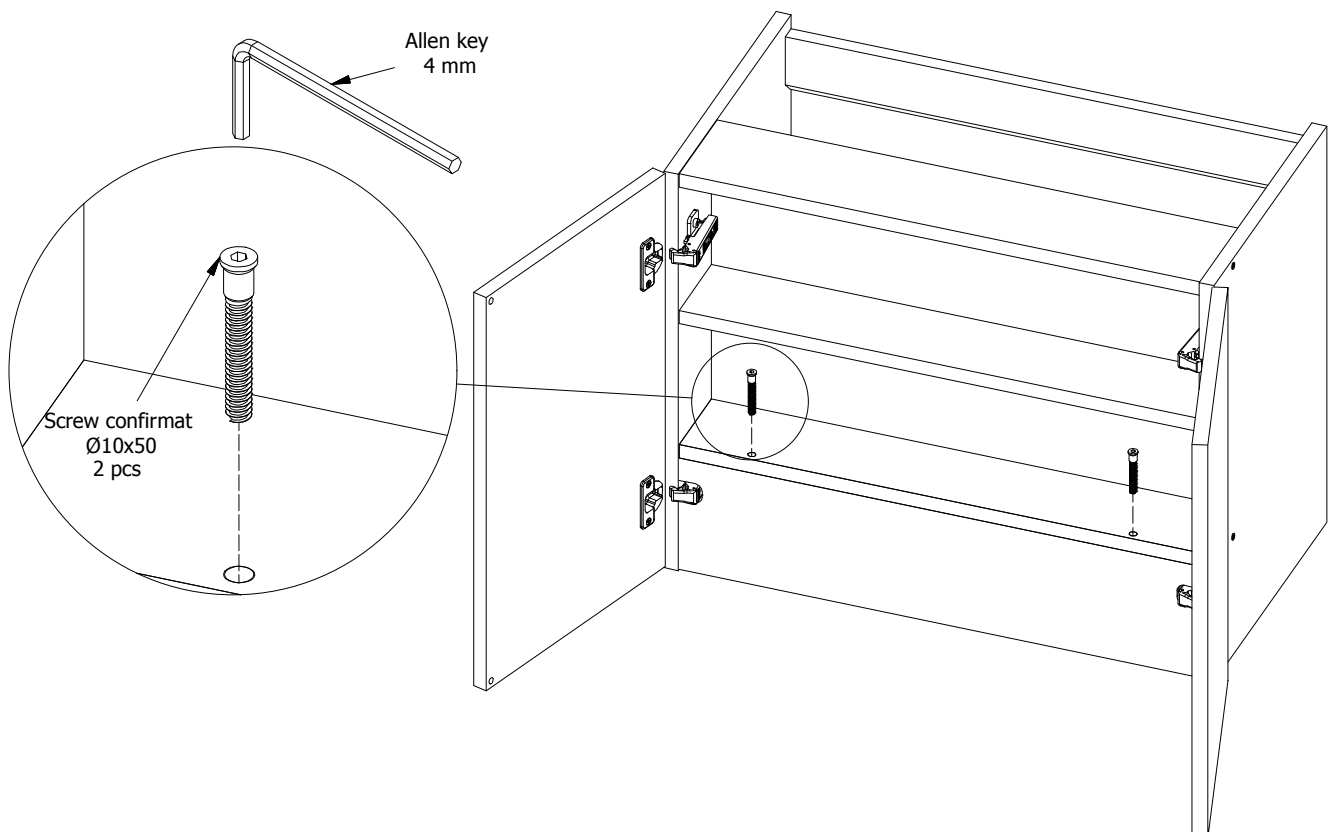

Fig 18



Adjustment

